

Installation Manual

Vehicle Tracking Device (VTD)



www.aircept.com

Table of Contents

Introduction.....	3
Safety Statement.....	3
Common Tool List.....	4
VTD and Mounting Locations.....	5
Antennas and Mounting Locations.....	5
OBDII Wire Harness.....	6
Standard Wire Harness Pin Connection.....	8
Standard Wire Harness.....	9
Basic Installation / Power Only.....	9
Basic Installation / With Optional Wiring.....	10
Starter Disable Diagram.....	10
Invert Polarity Diagram.....	11
Powering the VTD.....	11
Confirming Proper Operation.....	12
Motion Sensor.....	12
Bi-Colored LED Operation.....	13
Posi-Tap Instructions.....	13
Troubleshooting.....	14

Introduction

Satellites are in a 12-hour orbit at 12,000 miles above the earth. There are 24 satellites in the system and generally there are at least 5 satellites orbiting overhead at any one time. This antenna must be positioned to receive signals from these satellites. The antenna location must be selected carefully so that the antenna can receive the satellite signals. The standard GPS antenna is designed to be located inside the vehicle. The ideal location is in a place that allows line of sight reception from the GPS satellites in orbit above. The satellite signals will pass through glass if it is not coated with a metallic film. Both the radio transceiver antenna and GPS antenna is designed to be mounted inside the vehicle, **(not exposed to the outside weather)**.

Through formal agreements with cellular carriers throughout North America enabling the wireless transmission of data. This network covers virtually the entire population of the U.S, Canada, and Mexico that is within reach of the cellular network.

1. Safety Statement

This installation manual covers the installation of the Vehicle Tracking Device (VTD). This manual is for the professional and novice installer and should be used to ensure a safe and functional install of the VTD.

***Always a suggested practice to disconnect the vehicle's 12-volt system. There is no on-off switch on the unit. The installed unit operates 24 hours a day and must be energized to log vehicle events or send data as required by anyone using the service.

The VTD is shipped with one in-line 3-amp fuse attached to the power cable. This fuse must be installed as close as possible to the primary 12-volt source connection. The fuse protects the power cable should there be a short in the cable between the fuse and the VTD. This fuse must be installed properly. If the fuse is replaced, it should be of the same type as originally supplied from the factory. The original fuse supplied is a 3 amp 125-volt type 3AG (Little Fuse 321 Series).

Failure to use the proper fuse or to install the fuse in the recommended location could cause a vehicle fire hazard. The fuse provides overload protection for the power cable and VTD. The wiring installed between the fuse and primary vehicle power is not protected from overheating if a short should occur. Use care when routing the power cable and fuse. Route the cables where they will be protected and use commonly accepted install practices for after market automotive electronic devices.

There are three acceptable methods of making a wire connection:

- Soldering your connections (recommended)
- Crimp connectors (with the use of the proper crimping tool)
- Posi-Tap connectors (supplied in package)

Regardless of the method you choose, ensure that connection is mechanically sound and properly insulated. Use high quality electrical tape or shrink tubing, cheap tape will unravel in hot weather making it a poor insulator.

Not recommended connections:

- T-tap connectors (poor quality mechanical type connection)
- Twist and tape without soldering your connection.

*** **Using these connection types could result in numerous start up notifications*****

2. Common Tool List

- Magnetic bit holder that houses Phillips and flat-head bits
- Wire stripper and cutters
- Crimpers for insulated connectors
- Soldering iron & solder
- Tools to remove internal vehicle trim (panel popper, sockets, ratchet, screwdrivers, torx & hex bits, etc.)
- Butt connectors (various sizes)
- Ring terminal connectors (for grounding wire)
- Self tapping screws (various sizes)
- Star washers for grounding (strongly recommended)
- Electrical tape
- Wire 18 gauge
- Velcro and/or double sided tape (for mounting antenna)
- Wire ties (various sizes)
- Digital Multi Meter (see below)

Using Your Digital Multi Meter

The best solution, as it has always been, is a good digital multimeter. Not all air bag wires are in yellow tubing, and not all transistorized outputs can light a test light bulb without shorting out!

How to Find (+) 12V Ignition with Your Multi Meter

1. Set your meter to DCV or DC voltage (12V or 20V is fine)
2. Attach the (-) probe of the meter to chassis ground.
3. Probe the wire you suspect of being the ignition wire. The steering column is an excellent place to find this wire. Your meter should read (+) 0V.
4. Turn the ignition key to the "ON" position. If your meter reads (+) 12V go to the next step. If it doesn't probe another wire.
5. Now turn the key to the start position. The meter display should stay steady (+) 12V, not dropping by more than a few tenths of a volt. If it drops close to or all the way to zero, go back to step 3. If it stays steady at (+) 12V you have the ignition wire.

How to Find (+) 12V Starter Wire with Your Multi Meter

1. Set your meter to DCV or DC voltage (12V or 20V is fine)
2. Attach the (-) probe of the meter to chassis ground.
3. Probe the wire you suspect of being the starter wire. The steering column is an excellent place to find this wire. Your meter should read (+) 0V. Note: Remember you do not have to interrupt the starter at the same point you test it. Hiding the starter kill is always recommended.
4. Turn the key to the "ON" position, your meter should still read (+) 0V. Not: Make sure the car is not in gear. Now turn the key to the "START/RUN" position if the meter reads (+) 12V when the engine is cranking. Go to the next step. If it doesn't probe another wire.
5. Cut the wire you tested and attempt to start the car. If the starter will not turn over you have the right wire. If it still starts reconnect it and go back to step 3.

3. VTD and Mounting Locations

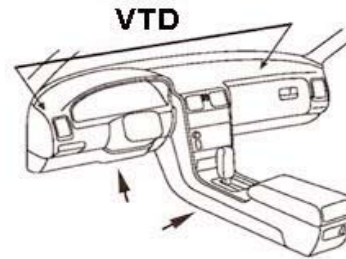

The unit should be mounted so it will not be exposed to damage from people or objects. The cables that connect to the unit should also be routed to protect them from possible damage. The VTD has mounting base or flange with four mounting holes. Normal installation is with these four holes and #6 or #8 sheet metal screws. The unit must be mounted where it will not be exposed to direct sunlight or excessive heat generated by the vehicle operation. Some examples of mounting locations include under the dash above the knee bolster, under center console, behind glove compartment, and in the trunk. If the optional battery is to be installed there should be room to mount the battery within 1 ft of the VTD.

The unit has a test wire and LED that will be used to verify operation by the installer. These items are normally not used by the owner.

4. Antennas and Mounting Locations

The VTD requires two antenna elements. One antenna is for receiving GPS signals from The Navistar GPS satellites. The second antenna is a radio transceiver antenna that communicates with the cellular network. The antenna does not require a ground plane to function properly.

There are two antenna cables in addition to the main power harness that must be connected to the VTD. If an exterior installation location is required you will need to use the optional antennas designed for exposure to the outside elements.

Antenna location is critical to the operation of the system. The antenna provided can be installed as a combined GPS/RF antenna or separately for easy installation. The GPS antenna must be mounted flat with the GPS receiver facing up (square portion of antenna, see picture). Ensure excess antenna cables are wrapped in a figure eight and mounted away from the device and antenna (see picture).

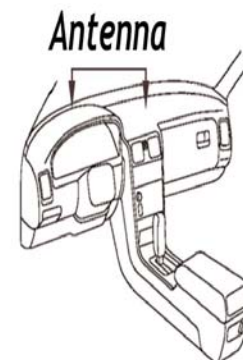

The largest antenna connector is for the GPS, the smallest connector is for the Communications.

5. OBDII Wire Harness / Power Only

The OBDII Wire Harness requires connection to the vehicle OBDII diagnostic connector. This connection will provide constant power and ground to the VTD.

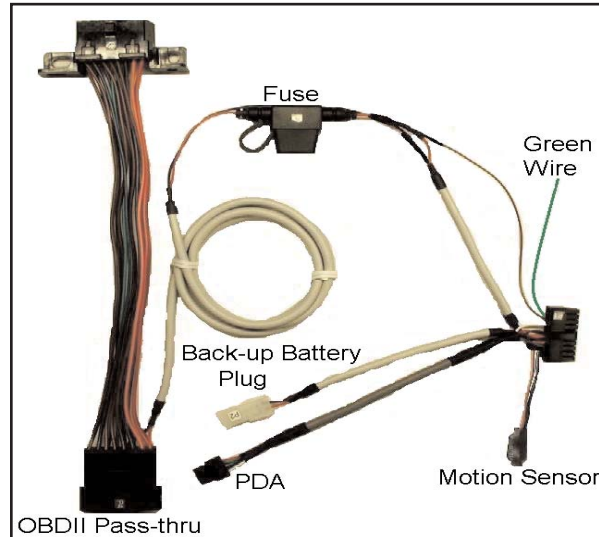

The OBDII connector is typically located on the drivers side, under the dash. Remove the OBDII connector from the current vehicle mounting position.

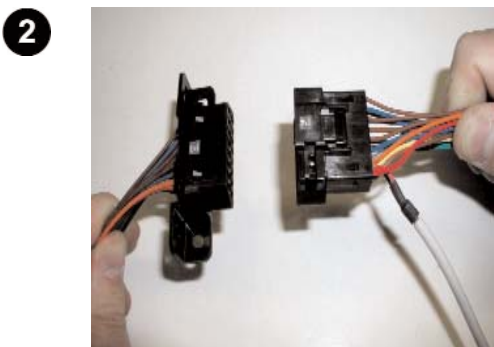

Plug the wire harness into the vehicles OBDII connector.



Remount the OBDII that is on the wire harness to the vehicles mounting position.

Note: The green wire is not used for the power only installation.

Note: The ignition wire is connected to constant power when using the OBDII wire harness, any features dependent on ignition "on/off" may not be triggered unless the brown wire is connected to a separate source of true ignition. Refer to your configuration.

5. OBDII Wire Harness/Adding Starter Disable

The Starter Disable feature requires true ignition power (**a wire with +12VDC when the engine is cranking and running**) for proper operation. In order to have ignition power the ignition wire (brown) on the wiring harness will need to be cut, an in-line fuse (3amp max) “not supplied” must be added and connected to vehicle ignition power.

- 1 Cut the Ignition wire (brown) on the power harness close to the fuse, and tape the exposed end by the fuse with electrical tape to ensure there is no bare wire exposed.

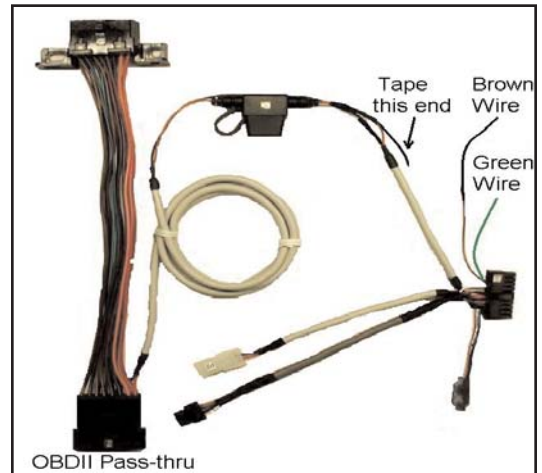
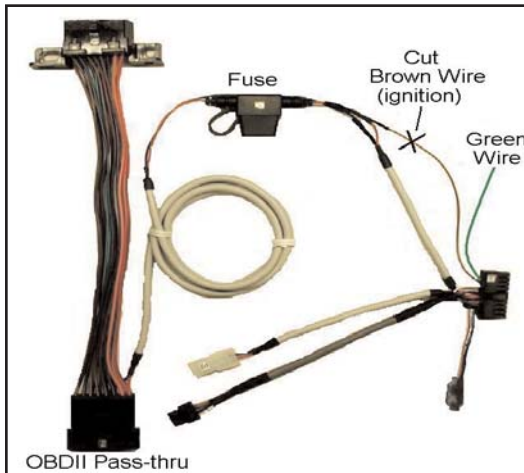

- 2 Using a butt connector, tie the brown wires from the disable relay and the power harness together and crimp them into one end of the butt connector.
- 3 Crimp another wire to the other side of the butt connector. This end connects through a fuse (3 amp max.) “not supplied” to the ignition wire of the vehicle.

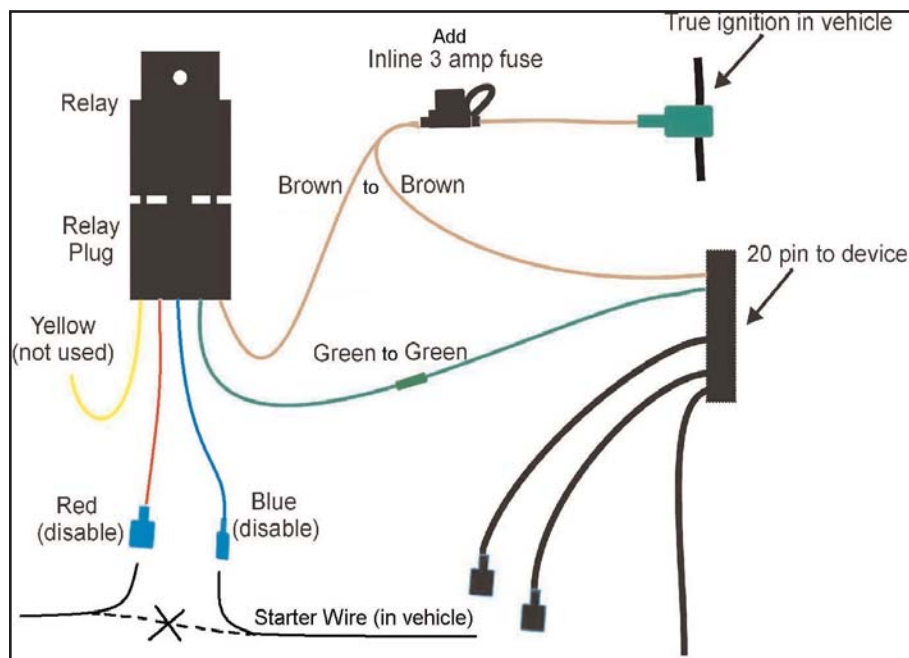

- 4 Using a butt connector, crimp the green wires from the power harness and the disable relay together.

6. Standard Wire Harness Pin Connection

Please refer to your Configuration Sheet to determine if any of the below listed output messages apply to your account.

PIN#	WIRE COLOR	DESCRIPTION	MESSAGE YOU RECEIVE WHEN TRIGGERED
P-1	BLACK	Ground Motion Sensor	
P-2	YELLOW	Remote "Door Unlock" neg double pulse (Output #1)	Doors Unlocked
P-3	GREEN	"Starter Disable Output" neg constant (Output #2)	Vehicle Disabled (If car is on) Starter Disabled (When car is off) Starter Enabled
P-4	ORANGE	"Alarm 1" or "Door Open/Closed" (15 sec neg trigger) (Input #1)	Alarm 1 Triggered Door Open/Door Closed
P-5	BLUE	"Geo-Fence Button" (2 sec neg to trigger) / "Alarm 2" (15 sec neg to trigger) (Input #2)	(If Geo button is used no message will be generated) Alarm 2 triggered
P-8	RED	Primary Power +12.6vdc	Start up Test (only on power up)
P-9	RED	Back-up Battery +12vdc	
P-10	BLACK	Primary Ground	
P-11	BROWN	Connected to Motion Sensor (cut then connect for Overheat or RSA (2 min neg to trigger) (Input #3)	"Motion Sensor" Geofence, Delivery Arrive / Delivery Leave, Unauthorized Movement "Brown wire only" Engine Over Heat / Road Side Assistance (RSA)
P-12	BLACK	Back-up Battery Ground	
P-14	GREY	Not used	
P-15	BROWN	TRUE Ignition Sense / Ignition On/Off (Input #4)	Ignition On / Ignition Off (If not programmed for ignition on/off no message will be generated)
P-16	WHITE / BROWN	Extra Output Trigger (Configurable Neg Output #3)	Extra Output Triggered
P-18	GREEN / YELLOW	Test Wire (15 sec neg trigger I/O'S)	
P-19	VIOLET	Geo-Fence or RSA LED flashing	
P-20	WHITE / YELLOW	Not used	

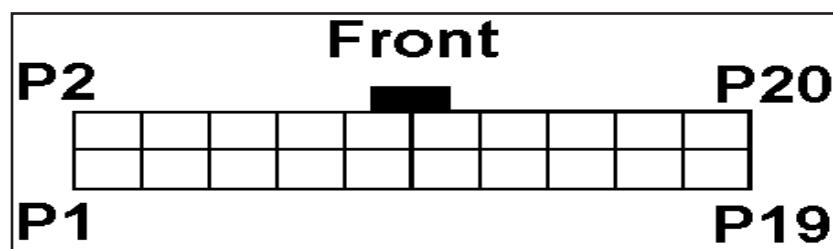

7. Standard Wire Harness

The Standard Wire Harness requires connection to power in the vehicle. This connection will provide constant power, ignition and ground to the VTD. This harness can also be used for optional features depending on the configuration of the VTD (please refer to your configuration sheet).

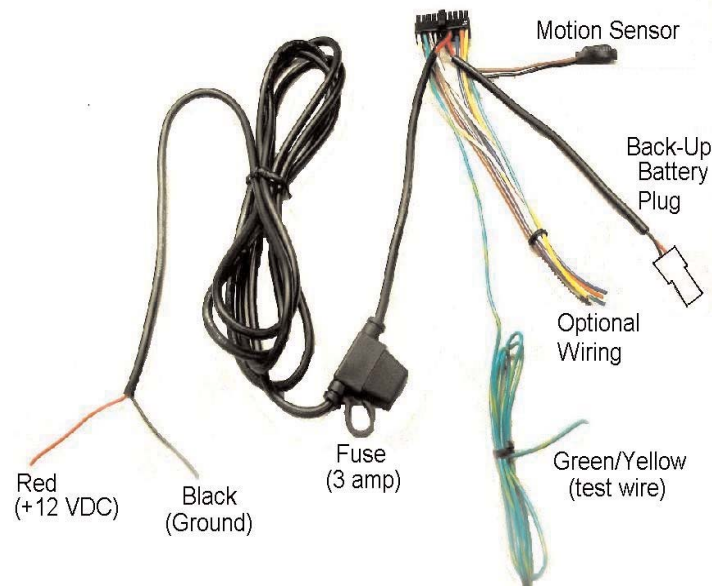

7.1 Basic Installation / Power Only

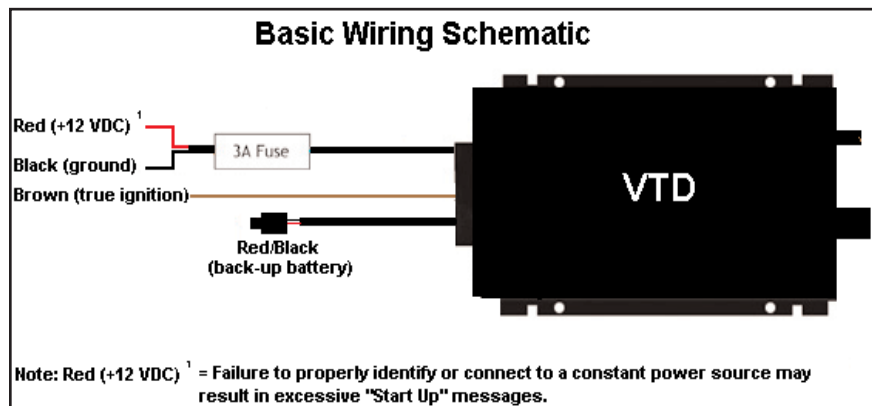

The following requires connection to the vehicle wiring harness.

- **Constant +12 VDC Power Wire (red)** +12VDC when the key is removed from the ignition.
Note: There is one 3 amp fuse inline.
- **Ignition Wire (brown)** +12VDC source of TRUE IGNITION.
Note: It is recommended to install a fuse inline (3amp max) "not supplied".
- **Ground Wire (black)** to a metal surface on the vehicle frame.

*Improper connection could result in numerous "Start up test" notifications, and increased usage on monthly billing.

7.2 Basic Installation / With Optional Wiring

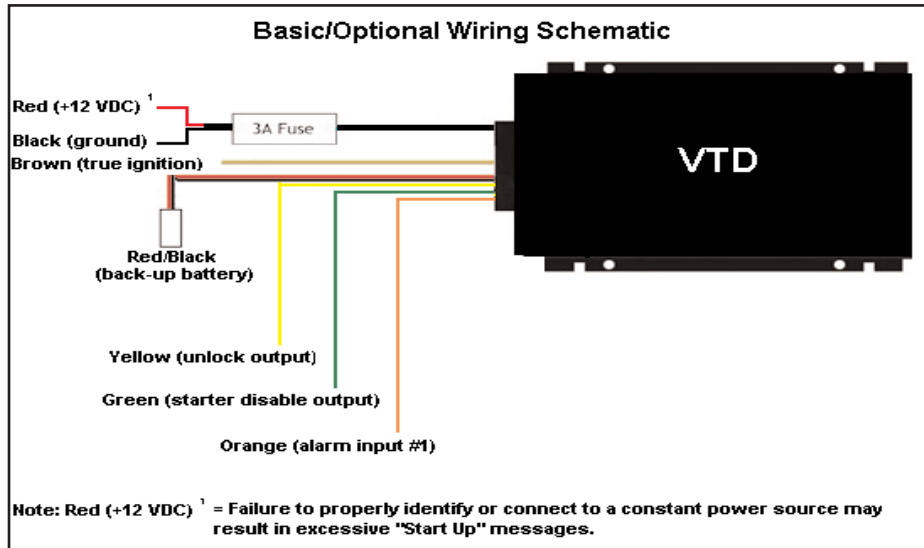

7.3 Starter Disable Diagram

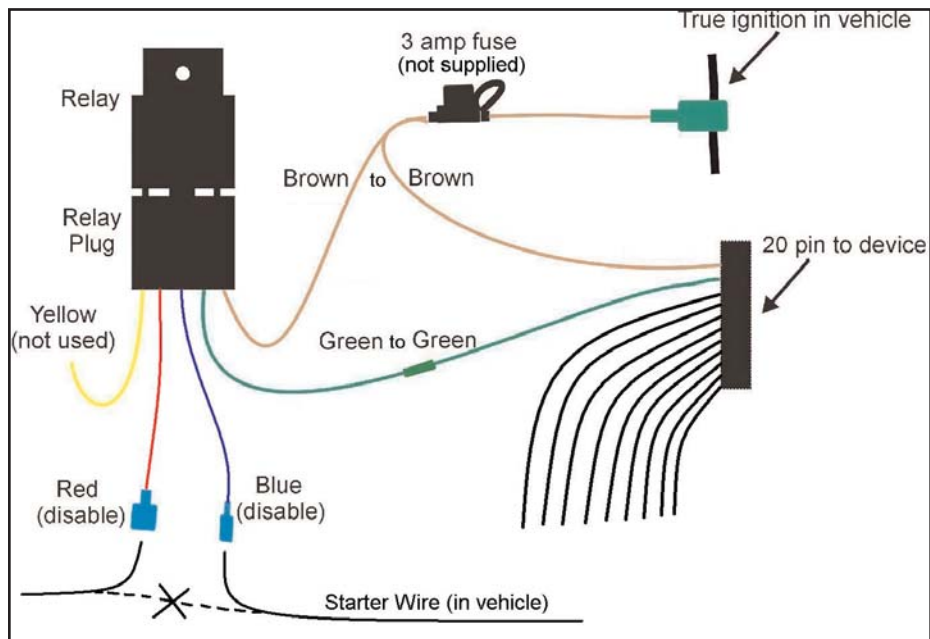

7.4 Invert Polarity Diagram for Door Unlock

Change polarity from negative to positive, used mainly for door unlock wires in vehicles that are positive trigger. Diodes and resistors may be required for some applications.

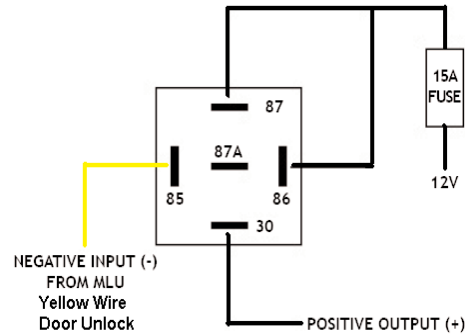

8. Powering the VTD

- 1**



Connect the two coax cables from the combination GPS/RF antenna to the VTD.
- 2**

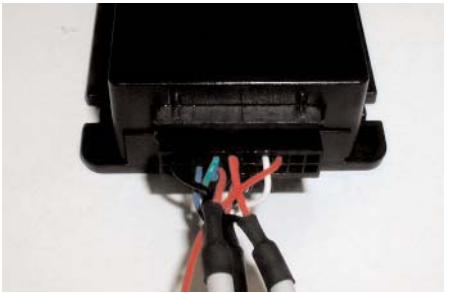

Plug the main harness into the VTD.
- 3**

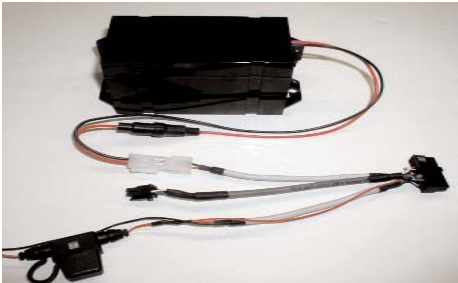

Plug the back-up battery into the wiring harness (if option available).

NOTE: The VTD should now be powered. There is a LED on the VTD that should now be flashing. Normal operation is with the LED flashing green 1 second “on” and 1 second “off”, this indicates GPS lock and Communication Service. This should happen in 5 minutes.

9. Confirming Proper Operation

Communication Service

During the initial 1 minute after +12volts is connected to the VTD, the LED should flash green at the rate of 1 second “on”, 5 seconds “off”, to indicate there is good communication service and the device has registered on the network.

GPS Location

Within five minutes the flash rate will change to approximately 1 second “on” and 1 second “off”, to indicate the VTD has established a GPS “lock” with location and Communication Service.

Start-up Test

The VTD will automatically send this message “Start-up test” the first time it gets a GPS lock after being powered on, or 15 minutes after powering up if it still has not received a GPS lock. This message can only be sent a maximum of three times from the VTD before being “reset”. “Reset occurs when the test pin is grounded or re-configured with the configuration utility. If a “Start-up test” is not received a “Location request” should be performed.

Installation Test Mode (test wire green/yellow)

The Test Wire on the VTD can be used to test the Installation of the device and ensure that the inputs and outputs are properly connected. Running tests with this wire grounded will not send data to the call center. The user account does not need to be activated to run the tests.

If the test wire is grounded for ten seconds, the device will enter installation test mode until the ground is removed from the test wire or for a maximum of 4 minutes and 15 seconds (whichever comes first).

The VTD will display solid green so long as no inputs are being triggered.

If INPUT 3 “motion sensor” is not configured as a motion sensor, then the LED will turn solid orange when INPUT 1,2 or 3 is grounded, or when INPUT 4 “ignition” is powered.

If INPUT 3 “motion sensor” is configured as a motion sensor, then the LED will turn solid orange when INPUT 1 or 2 is grounded, INPUT 4 “ignition” is powered, or the device detects movement from the motion sensor.

On entering test mode, the unit will trip and reset:

- OUTPUT 1 “door unlock” (3 sec tripped pulse)
- OUTPUT 2 “starter disable” (30 sec)
- OUTPUT 3 “extra output” (3 sec)

After this, or if test mode is exited prior to the completion of this sequence, any tripped relays will be reset.

Entering Test Mode also resets the hours and mileage counts for all Auto Report and Maintenance messages. It also resets the count of start-up test messages back to 0. Exiting Test Mode causes any triggered outputs to reset and causes the LED to return to its normal (blinking) display.

Normal operation is with the LED flashing 1 second “on” and 1 second “off”, this indicates GPS lock and Communication Service.

10. Motion Sensor

The VTD is designed to work with a motion sensor to provide a safeguard against normal GPS drift. The motion sensor is included as part of the harness and connects to INPUT 3. INPUT 3 is thus unavailable for other use if a motion sensor is connected. If the sensor is sensing movement for longer than 3 seconds, the device is considered “moving”. If there is no movement detected on the sensor for more than 30 seconds, the device is considered “resting”. In test mode, the LED color is affected by whether the device is “moving” or “resting”. In normal operation, if the device is configured to use the sensor, then neither the Fixed Boundary, Moveable Boundary (Geofence), nor Towing Alarm Violations will be sent if the device is not “moving”. Also, if the Emergency Track or Destination Track reports are configured to trigger after a certain distance (displacement) is traveled, then the device will not trigger such a report based on GPS location criteria alone unless the device is “moving”.

11. Bi-Colored LED Operation:

Each VTD is equipped with one bi-colored LED, located between the two antenna connectors.

Solid LED Colour:

- **Solid Green:** VTD is in Test Mode; no inputs are currently being triggered.
- **Solid Orange:** VTD is in Test Mode; at least one input is currently being triggered.
- **Solid Red:** VTD is in Setup Mode.

Blinking LED Colour:

- **Blinking Green:** Communication Service is fully available.
- **Blinking Orange:** A Communication Service has been detected, but is not usable.
- **Blinking Red:** No Communication Service has been detected.

Blinking LED Timing:

- **Off for 1 second:** GPS Module is powered and signal is Valid, Cell Module is powered.
- **Off for 5 second:** GPS Module is powered and signal is Invalid, Cell Module is powered.
- **Off for 10 seconds:** GPS Module is turned off, Cell Module is powered.
- **Off for 21 seconds:** GPS Module is powered and signal is Valid, Cell Module is turned off.
- **Off for 25 seconds:** GPS Module is powered and signal is Invalid, Cell Module is turned off.
- **Off for 30 seconds:** GPS Module is turned off, Cell Module is turned off.

Note: It is highly recommended to perform a location request and other optional features before releasing the vehicle.

12. Posi-Tap Instructions:

A Posi-Tap may be included in the installation kit. This connector may be used to connect to power in the vehicle.

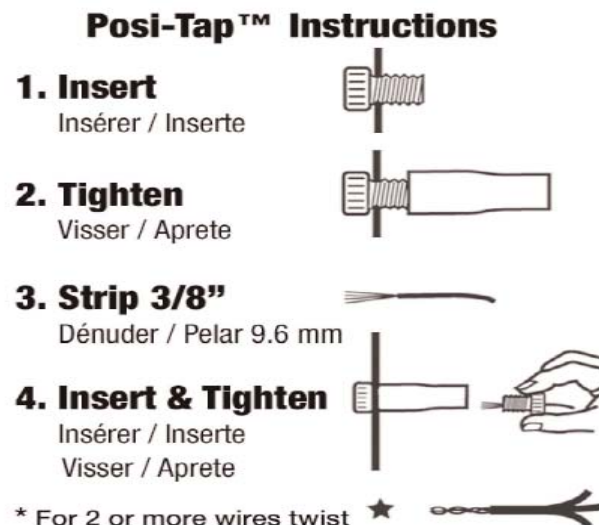

Patent # 5,228,875 5,695,369 5,868,589 6,692,313B1
6,568,952B1 Jap 2881414, Aus 708700, Tia 103534, Can
2204826, Mex 200626 China ZI97105562.9, Korea 477279 and
others pending

13. Troubleshooting

1. I cannot locate my vehicle

	Possible Cause	Action Required
1.	No power to unit.	Check all connections. The LED should be flashing.
2.	Blown/Loose fuse.	Replace or tighten fuse.
3.	Low car battery.	Replace or charge battery. Start the vehicle.
4.	Poor cell coverage.	Drive vehicle to different area.
5.	Poor antenna location.	Reposition the antenna.
6.	Wrong serial number.	Verify S/N on device with the website.
7.	Test wire is grounded. (green/yellow)	Remove test wire from ground.

2. Vehicle engine will not start:

	Possible Cause	Action Required
1.	Wrong wires connected.	Make sure correct wires are connected
2.	Incorrect power source.	Establish good power source before cranking and during cranking.
3.	Incorrect ignition source.	Test ignition wire (brown) for true ignition source.
4.	Loose chassis ground.	Ensure ground is secure to the metal chassis.

3. Unit responds but I get no map:

	Possible Cause	Action Required
1.	Poor antenna location.	Reposition the antenna ensuring no metal above and is laying flat with gps receiver facing upwards.
2.	Vehicle in or near building.	Move vehicle to open area.
3.	Not enough voltage to unit when vehicle is off.	Ensure brown wire is connected to ignition. Turn car on, this should wake unit from power management mode.

4. No "Start Up" message:

	Possible Cause	Action Required
1.	The VTD should be programmed to send in a maximum of 3 start-up messages.	The Test Wire can be grounded to reset the message count to 0.

5. When I track my vehicle no map comes up and returns me to the login page:

	Possible Cause	Action Required
1.	Pop up blocker.	Disable/turn off pop up blocker. Do not use AOL browser.

6. I login, but when I try to use any features it takes me back to the login page:

	Possible Cause	Action Required
1.	Cookies accepted.	Disable/turn off cookies blocker. Delete cookies and temporary internet files.